

Model-DSSP5030 X-ray Baggage Scanner

DSSP5030 used in penetrate inspection, can detect the object metal structure, display where is invisible to the naked eye. Used in the factory products testing and public institution security check such as: electronic factories, exhibition, shoe factories, toy factories, courts, railway stations, customs, terminal and large-scale activities package security check.

■ Application



■ Features

- ✓ Alarm by sounds & light: Alarm by sounds and light when conform to condition.
- ✓ Network interface: Could be connect local area network and support multi-terminal check baggage at same times.
- ✓ Safety ray: Transmit ray under automatic control, avoids the miss.
- ✓ Image monitoring for user-friendly: The monitor use fold, rotary system, operators adjust the monitor position willfully according to own need, reduces wearily.
- ✓ Simple operation by mouse: Without keyboard and work table, control by mouse, save space.
- ✓ Turn off by a key control: Turn off the machine only need one step: revolves the key. The equipment automatic security close-down, does not need complex many steps, is simpler.
- ✓ Eagle-eye: Could be expediently observing enlargement area.
- ✓ Estimate malfunction by self: Automatic estimate malfunction and prompt message, helpful for the maintenance.

X-ray Generator

- Generate Direct: Vertically Upward
- Generate Angle: 60 degree
- Anode Voltage: 80Kv(adjustable)
- Anode Power: 0.4 to 0.5mA(adjustable)
- Cooling / Duty Cycle: Oil Cooling /100%

Image System

- X-ray Sensor: L-Shaped Photodiode Array (Single-energy), 12bit Deep.
- Monitor: High Resolution Color, LCD Accord, 19 inch
- Image Processing: Edge enhancement, image strengthening, image lightening, reducing darkening, image returning, and image retrieval.
- Image Grey Level: 4096
- Image Max Resolution: 1024 * 1280 pixel
- Image Processing: 24bit for processing real time
- Image storage: Storage 10000 pictures in real time
- Color quality: 32 bit real colors.

■ Specifications

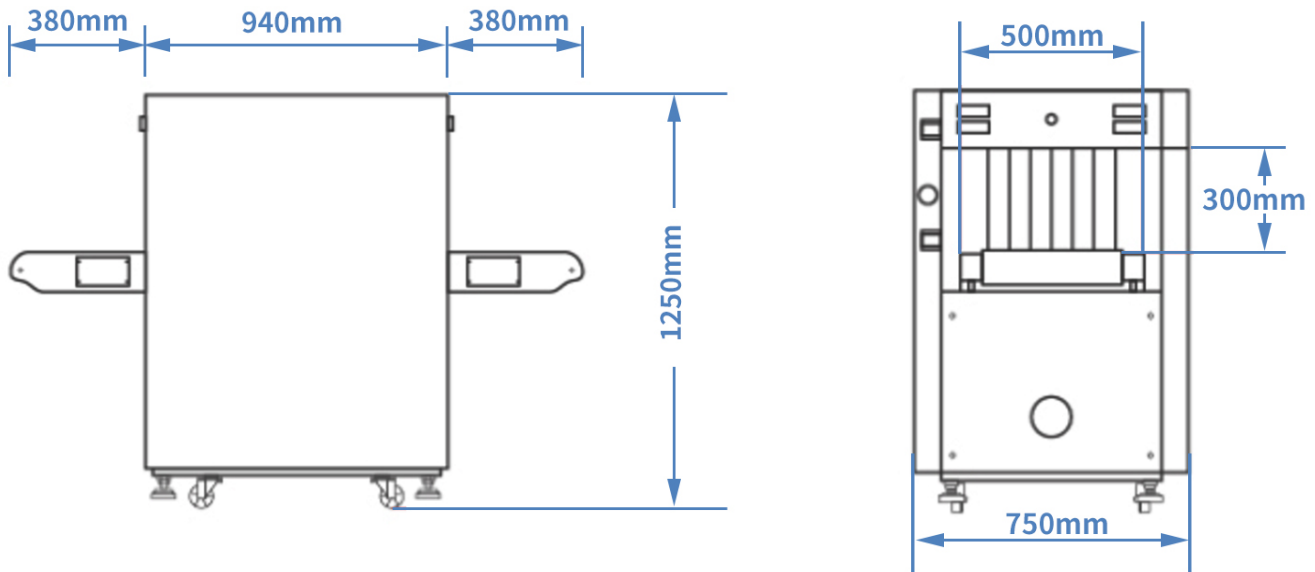

Model No.	DSSP5030
Brand	DAOSAFE
Color	Deep Blue
Tunnel Size	500(W)×300(H)mm
Dimension	170cm(L)x75cm(W)x125cm(H)
Work Station (Single Screen) Size	76cm(L)x77cm(W)x138cm(H)
Gross Weight	350kg
Conveyor Speed	0.22m/s
Conveyor Max Load	180kg belt
Dose per Inspection	less than 1.0μGy/h
Wire Resolution	0.0787mm Copper Wire
Spatial Resolution	Level: dia1.0mm, Vertical: dia1.3mm
Penetration	14mm Steel
Film Safety	Guarantee ISO1600 Film
X ray Leakage	less than 0.2μGy/h
Monitor	Philip high resolution 19inch color LCD display
Operation Temperature/Humidity	0°C-45°C/20%-95%(non-condensing)
Storage Temperature/Humidity	-20°C-60°C/20%-95%(non-condensing)
Operation Power	220VAC(±10%)50±3Hz
Power Consumption	1.0KW(max)

Project Reference



