



Model DS-Q50S

Quantum Tripod Turnstile (Twin type)

DS-Q50S Tripod Turnstile with twin rotating arms. Its main advantages:

- Combines galvanized steel body with a sleek tempered glass top, offering a sophisticated and durable solution at an exceptional value.
- The twin-rotating-arm design with two passageways enables smooth, one-person-at-a-time flow, significantly improving traffic throughput.
- With anti-trailing function, only one person to pass at one time, effectively preventing unauthorized trailing.
- Design with classic black, white color appearance, elegant and timeless pairing, perfect for using at high end applications.

Features

- Two way or one way working.
- Support integrated with any type of access control systems.
- Lower power consumption.
- Low noise, system runs smoothly.
- Green and red LED indicator display passing status.
- Fire safety requirements, arms drop down automatically.
- Easy to install and maintain.
- 3 years warranty support.

Customized Service

- Appearance color can be customized based on installation environment.
- Dimensions can be customized to meet your request.
- Logo can be customized.
- Reader mount space can be customized.
- Waterproof outdoor can be customized.
- Base optional: can add DSSP6005 base
- Picture: high resolution and 3D renderings pictures can be customized.
- The wireless remote control is available as a customized option, allowing front-desk staff to control the gate directly.



Logo Custom

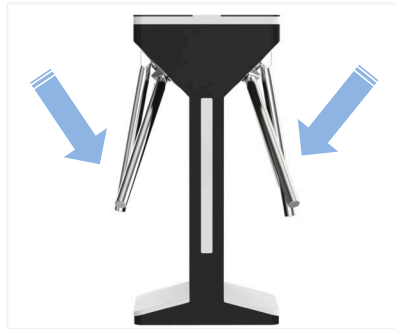

Arms Drop Down

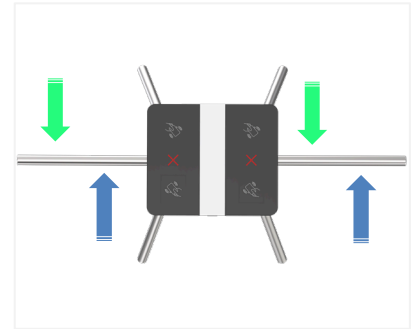

Single/Bi-directional



LED Indicator



Two-way Passage



Anti-trailing Function

Access Control System

Daosafe turnstile gates can be well integrated with any 3rd party access control systems



Card Solution

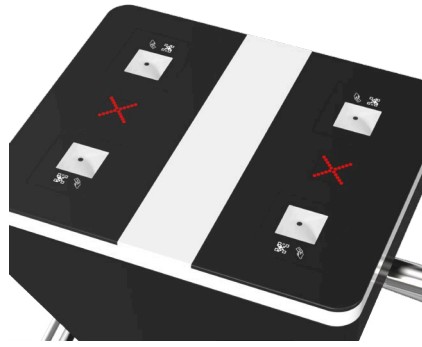

QR/Bar Code Solution



Biometric Solution



Remote Control



Touchless Button



Card



QR Code



Fingerprint



Face





Palm Vein

4 lanes for card solution installed at swimming pool



Specifications

Model No.	DS-Q50S
Type	Quantum Tripod Turnstile (twin type)
Brand	Daosafe
Certifications	Compliance CE, ROHS, FCC
Framework Material	Galvanized steel White and black powder coated
Arm material	304 Stainless Steel
Dimension	470(L)*400(W)*1000(H)mm
Net Weight	60kg/pcs (double core)
Passage Width	550mm + 550mm (arm 500mm)
Passing Direction	Single directional/Bi-directional
MCBF	10 million
Power Supply	AC220V/110V, 50/60Hz
Operation Voltage	24V DC
Power Consumption	40W + 40W
Operation Temperature	-20 °C ~ 75 °C (can be customized)
Operation Humidity	0 ~ 95% (No freeze)
IP Level	IP54 (standard), IP65 (can be customized)
Working Environment	Indoor/Outdoor (can be customized)
Flow Rate	35 + 35 people per minute
LED Indicator	Authentication Status Light:  turns  (on valid scan)
Card Reader Mount	Under the top of the cabinet Max. dimensions: 100(L) * 80(W) * 25(T)mm (can be customized)
Emergency	Arm drop down automatic when power off
Communication	Dry contact, Relay signal, RS485
Flexibility	Integrate with any access control

Dimensions

Parameter	Standard	Recommended	Optional	Note
Arm Width	500mm	/	600mm (can be customized)	If need disabled lane, DSSP6003ABC or DS8000 are optional
One Arm	DS-Q50 tripod turnstile is optional.			

Front View

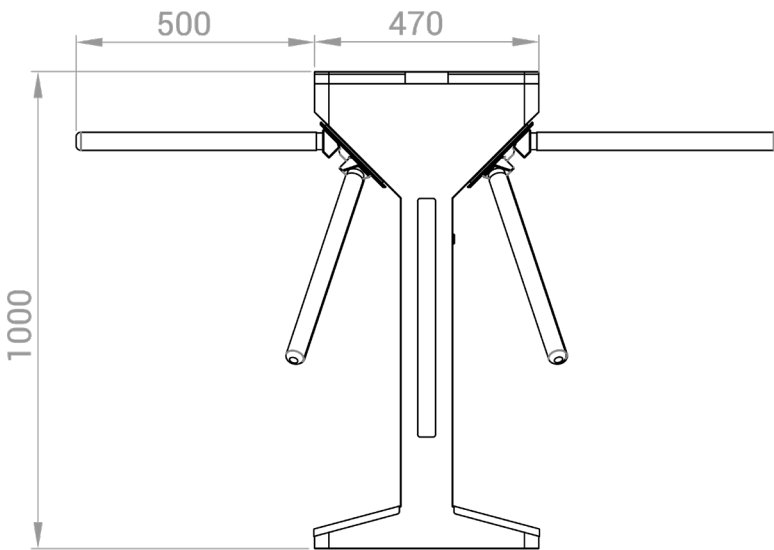

Side View

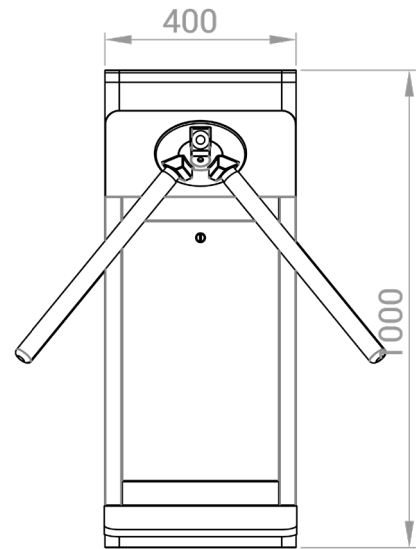

Top View

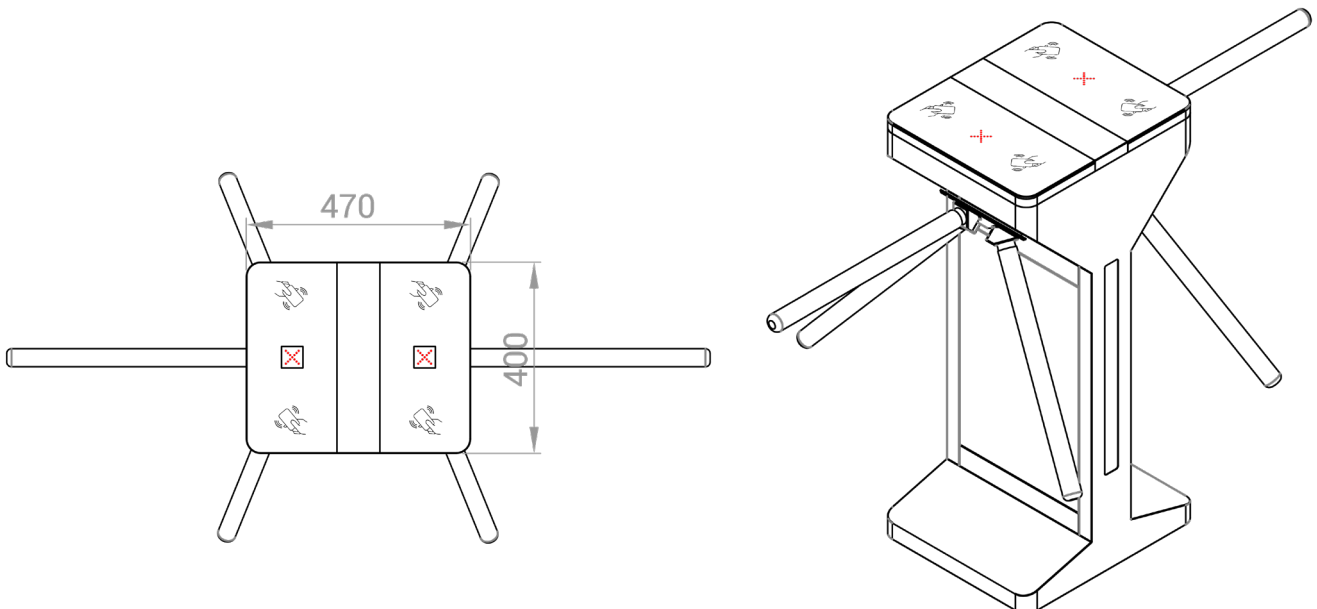

Lanes Solutions



Two Lanes



Four Lanes with Disabled Access

Color Customization



Standard Color



Black Powder Coated



White Powder Coated

DS-Q50S and DS8000 disabled lane installed at library



4 lanes DS-Q50 customized color installed at entrance

