



Model DSN-30

Nebula Flap Turnstile

DSN-30 is a flap turnstile product in the Daosafe Nebula series, with the following advantages:

- It supports passage width standard 600mm, faster open and close speed than other turnstile gates, normally 45 persons per minute which is perfect for the sites with big visitor's flow rate.
- Featuring a unique classic design, the arm added dazzling LED strips, LED strips are seamlessly embedded in various parts of the case, making it modern and stylish.
- Constructed with a solid-body structure, the crate combines brushed stainless steel, high-end black powder coating, and side-mounted tempered glass, ensuring exceptional sturdiness.
- Ideal for installation in any high - end and elegant scenario, leaving a strong impression.

Features

- Two way or one way working.
- 304/316 stainless steel material.
- Support integrated with any type of access control systems.
- 0.1s fast open speed, 45 person/min high throughput.
- Lower power consumption.
- Low noise, system runs smoothly.
- Blue, green and red LED indicator display passing status.
- Fire safety requirements, arms open automatically.
- Easy to install and maintain.
- 3 years warranty support.

Customized Service

- Appearance color can be customized based on installation environment.
- Dimensions can be customized to meet your request.
- Logo can be customized.
- Reader mount space can be customized.
- Arm glass width is optional.
- Waterproof outdoor can be customized.
- Infrared sensor number optional.
- Picture: high resolution and 3D renderings pictures can be customized.
- The wireless remote control is available as a customized option, allowing front-desk staff to control the gate directly.

Functions

- **Infrared sensor alarm function:**
in case of illegal intrusion and reverse intrusion.
- **Anti-intrusion function:**
the gate is locked automatically until valid opening signal input.
- **Anti-reverse function:**
the turnstile alarms if someone wants to entry in the reverse direction.
- **Anti-trailing function:**
the speed gate alarms if someone wants to burst in without permission.
- **Anti-collision and anti-kick function:**
it designed with consolidated and more durable mechanism, will not break even someone collide it.
- **Mechanism self-protection:**
the arm will reset automatically if off position. The movement will not be broken or damaged even hit.

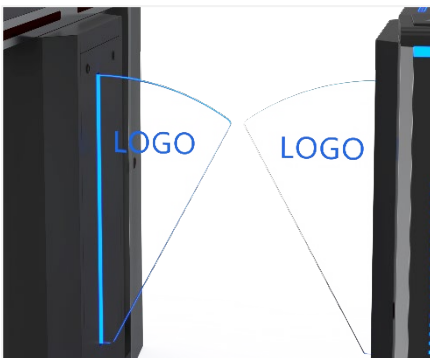

Logo Custom



LED Indicator

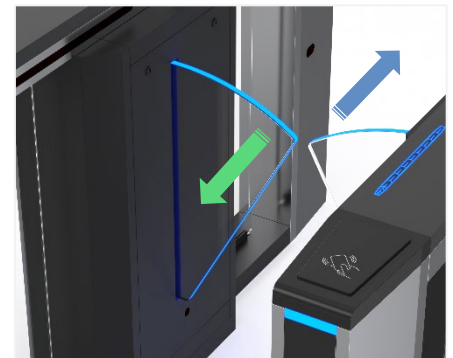

Bi-directional Passage



Anti-reverse Function

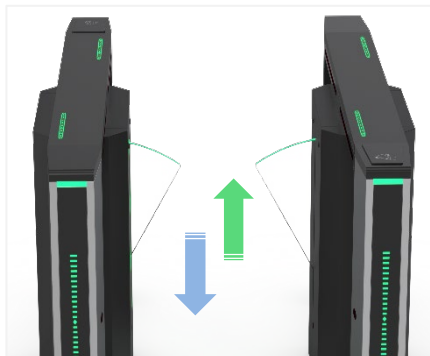

Fire Safety Requirements,
Arms Open Automatically



Anti-trailing Function

Access Control System

Daosafe turnstile gates can be well integrated with any 3rd party access control systems



Card Solution



QR/Bar Code Solution



Biometric Solution



Remote Control



Touchless Button



Card



QR Code



Fingerprint



Face



Palm Vein

4 lanes DSN-30 with card solution installed at school



Specifications

Model No.	DSN-30
Type	Nebula Flap Turnstile
Brand	Daosafe
Certifications	Compliance CE, ROHS, FCC
Framework Material	304 brushed stainless steel+ High end black powder coated
Arm Material	Plexiglass 15mm (standard) Tempered glass 10mm (optional)
Dimension	1600(L)*280(W)*980(H)mm
Net Weight	75kg/pcs (single core), 95kg/pcs (double core)
Passage Width	600mm (standard)
Passing Direction	Single directional/Bi-directional
MCBF	10 million
Power Supply	AC220V/110V, 50/60Hz
Operation Voltage	24V DC
Power Consumption	40W
Operation Temperature	-20 ~ 75°C (can be customized)
Operation Humidity	0 ~ 95% (No freeze)
IP Level	IP54 (standard)/IP65 (can be customized)
Working Environment	Indoor/Outdoor (can be customized)
Flow Rate	45 people per minute
LED Indicators (Strips)	Blue color: power on, green color: entry, red color: no entry
Infrared Sensor	7 pairs(standard)
Card Reader Mount	Under the top of the cabinet Max. dimensions: 140(L)*60(W)*25(T)mm (can be customized)
Communication	Dry contact, Relay signal, RS485
Emergency	Automatic arm open when power off
Flexibility	Integrate with any access control

Dimensions

Parameter	Standard	Recommended (disabled)	Maximum	Note
Passage Width	600mm	/	/	If need disabled lane, Nebula series DSN-20 DSN-70 or DS8000 are optional.
Arm Width	550mm	/	/	

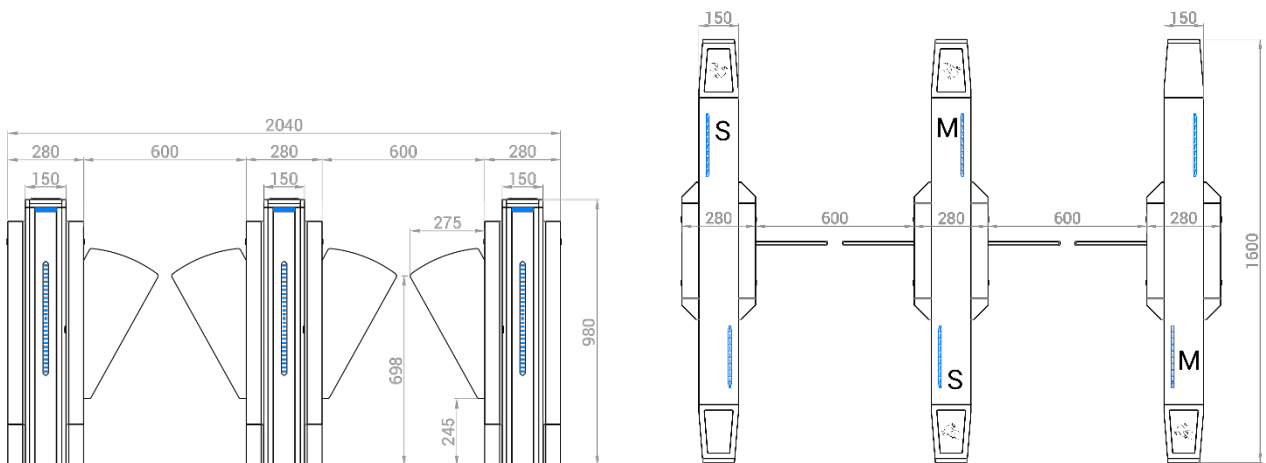
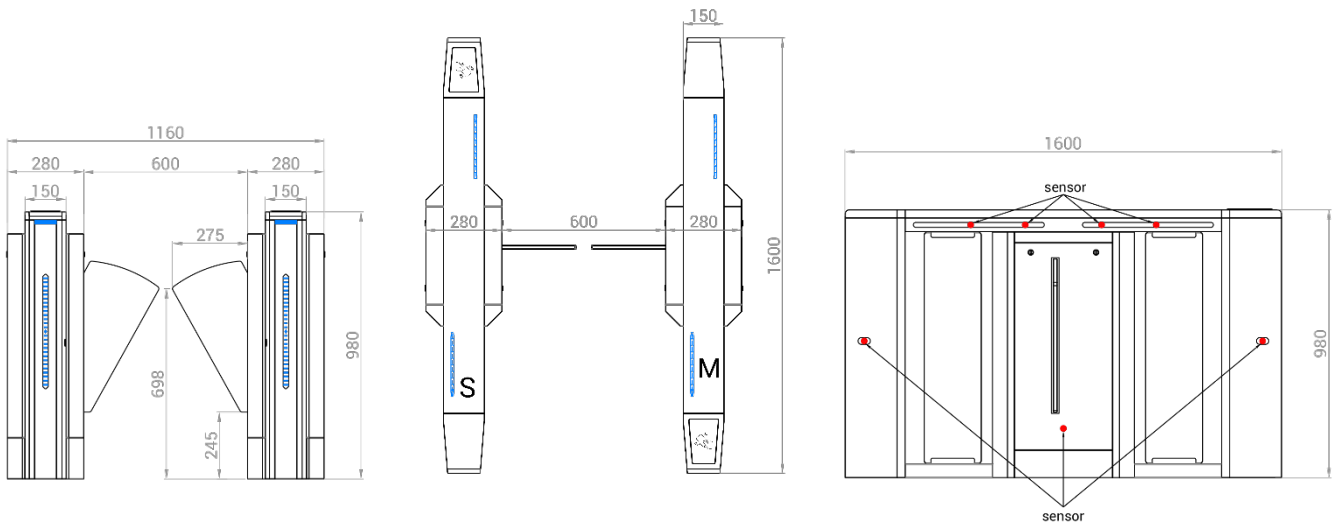

Lanes Solutions



One Lane



Two Lanes



Two Lanes with Disabled Access

Color Customization



Black Powder Coated



Stainless Steel Material



Grey Powder Coated

3 lanes DSN-30 with disabled lane DSN-20 installed at hotel



2 lanes DSN-30 with disabled lane DS8000 installed at museum

