



Model DSN-50P

Portable Turnstile

DSN-50P Portable Turnstile with four major advantages:

- The most notable feature of portable turnstile is convenience and portability.
- It consists of a turnstile, mounting platform, railing, and wheels.
- It is suitable for various scenarios such as exhibitions, lawns, gardens, construction sites, etc., allowing easy mobility and usage without the need for bolt fixation to the ground.
- The product's structure is exceptionally sturdy, making it suitable for installation in any environment.

Features

- Two way or one way working.
- 304/316 stainless steel material.
- Support integrated with any type of access control systems.
- Lower power consumption.
- Low noise, system runs smoothly.
- Green and red LED indicator display passing status.
- Anti-tailing function: only one person passes at one time.
- Fire safety requirements, arms drop down automatically.
- Easy to install and maintain.
- 3 years warranty support.
-

Customized Service

- Appearance color can be customized based on installation environment.
- Dimensions can be customized to meet your request.
- Logo can be customized.
- Reader mount space can be customized.
- Waterproof outdoor can be customized.
- Picture: high resolution and 3D renderings pictures can be customized.
- The wireless remote control is available as a customized option, allowing front-desk staff to control the gate directly.



Logo Customization

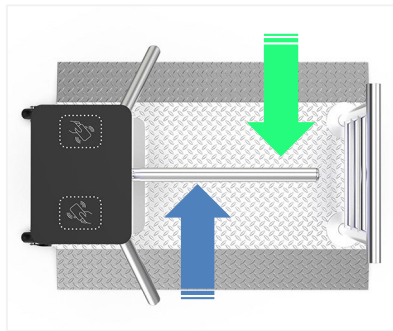

Single/Bi-directional Selectable



Movable Wheels

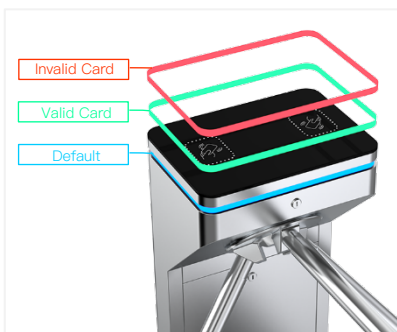

Three LED Indicators



Arms Drop Down

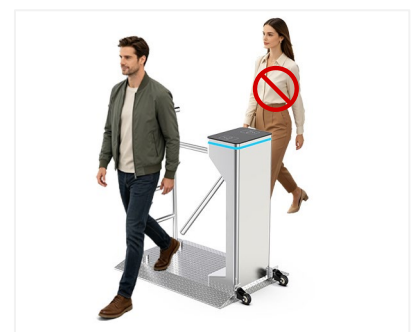

Anti-tailing Function: one person can pass at one time

Access Control System

Daosafe turnstile gates can be well integrated with any 3rd party access control systems



Card Solution

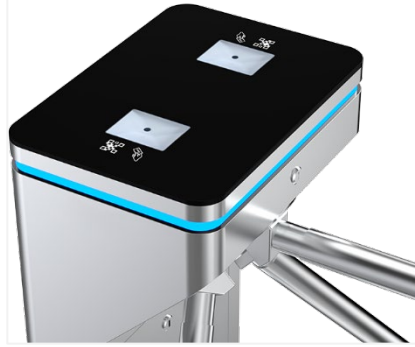

QR/Bar Code Solution



Biometric Solution



Remote Control



Touchless Button



Card



QR Code



Fingerprint



Face



Palm Vein

Five lanes for card solution installed at building



Working with DS225G
Nebula Swing Turnstile.

Specifications

Model No.	DSN-50P
Type	Portable Turnstile
Brand	Daosafe
Certifications	Compliance CE, ROHS, FCC
Framework Material	304 brushed stainless steel High end black tempered film glass
Arm material	304 Stainless Steel (Black rubber protector is optional)
Dimension	Turnstile: 360*260*980mm Base: 980*720*50mm Bar: 460*1020mm
Net Weight	Turnstile: 35kg/pcs Base: 10kg/pcs Bar: 5kg/pcs
Passage Width	550mm (arm 500mm)
Passing Direction	Single directional/Bi-directional
MCBF	10 million
Power Supply	AC220V/110V, 50/60Hz
Operation Voltage	24V DC
Power Consumption	40W
Operation Temperature	-20 °C ~ 75 °C (can be customized)
Operation Humidity	0 ~ 95% (No freeze)
IP Level	IP54 (standard), IP65 (can be customized)
Working Environment	Indoor/Outdoor (can be customized)
Flow Rate	35 people per minute
LED Indicator	Three LED indicators on top: Blue → default, green → valid, red → invalid
Card Reader Mount	Under the top of the cabinet Max. dimensions: 100(L) * 100(W) * 25(T)mm (can be customized)
Emergency	Arm drop down automatic when power off
Communication	Dry contact, Relay signal, RS485
Flexibility	Integrate with any access control

Dimensions

Parameter	Standard	Recommended	Optional	Note
Passage Width	550mm	/	/	If need disabled lane, DS225G or DS8000 are optional
Arm Width	500mm	/	/	

Front View

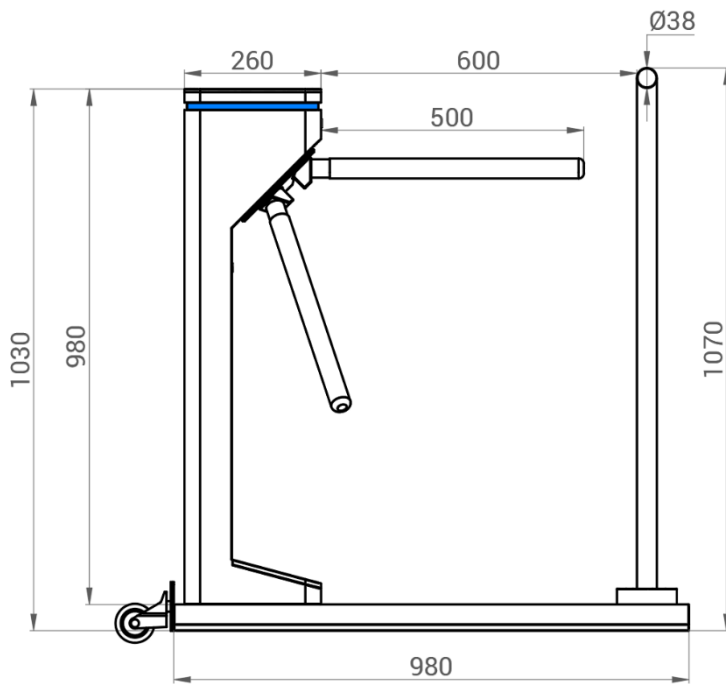

Side View

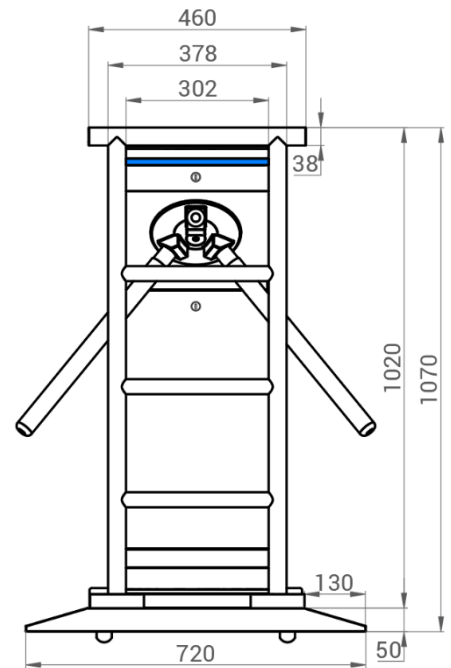

Top View

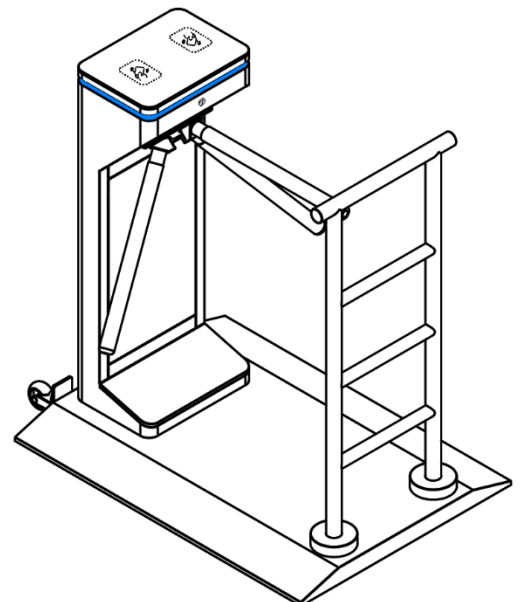
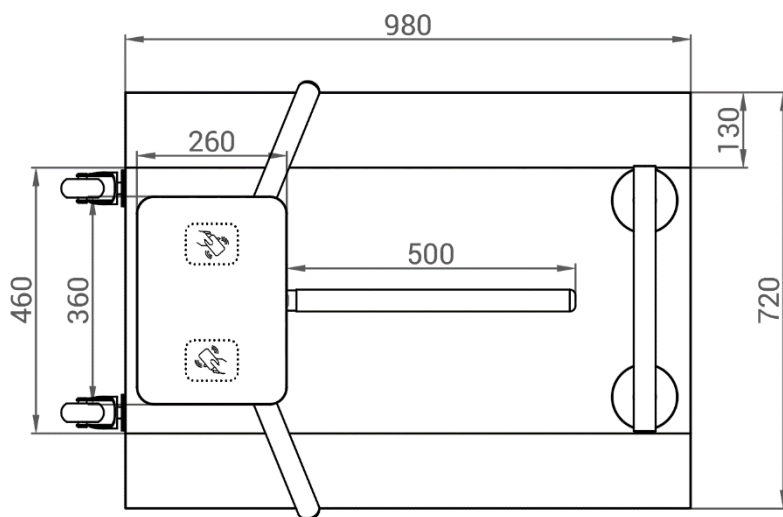

Five lanes for card solution installed at the park entrance.



Working with DS8000
Cylinder Speed Gate.

Four lanes for card processing have been installed in the office premises.

